

Classic Series Biological Safety Cabinet

HR30-IIA2/HR40-IIA2



Main Applications

Professional partial air purification equipment, it is suitable for cell biology, microbiology, biomedicine, biosafety and other related laboratories. It provides the most essential protection and isolation equipment for biosafety.

Qingdao Haier Biomedical Co.,Ltd.

No.280 Feng Yuan Road, High-tech Zone,
Qingdao, 266109, P.R. China
E-mail: inquiry@haierbiomedical.com
Website: www.haiermedical.com



Haier Biomedical
International



Haier Biomedical
International



@haiermedicalint



Haier Biomedical
International



Haier Biomedical
International

Biological Safety Cabinet: Classic Series, Type A2

Product Advantages



- Digital LCD screen
- Real-time display of key parameters: down-flow velocity, inflow velocity, airflow volume, static pressure, negative pressure, accumulative running time of fan, accumulative running time of UV lamp, and remaining life of filter
- Audible and visual alarms for abnormal parameters
- Clock setting function
- UV lamp sterilization timer function
- Quality 304 stainless steel operation platform without screws, no accumulation of contaminant
- Dismountable air in-flow plate, easy to clean and sterilize
- The internal walls on three sides of operation area is constructed by a single plate, and the 12mm arc angle corner leaves no hidden cleaning areas
- The volume of the liquid tank is over 4L, equipped with an outlet valve for convenient cleaning and maintenance
- Patented air flow blocking is adopted at the upper edge and both edges of the front window to eliminate the exposure of microorganisms

Ergonomic

- **UV Lamp One-touch Pre-set**
The UV Lamp can store the user's settings and habits, and can be preset with a certain startup delay just by pressing down one key, saving valuable time for the user
- **Universal Casters with Built-in Threaded Support Legs**
The underframe is designed with universal casters for moving the cabinet conveniently, and the built-in threaded support legs can prevent the propagation of bacteria

Professional

- **Digital display of operating parameters**
Real-time digital display of down flow, inflow, exhaust volume, filter remaining life, UV lamp remaining life, negative pressure and positive pressure

Safe

- Abnormal operation condition alarm

Audible and visual alarms in the form of voice or text will be presented when the air level exceeds 20%, and door height (high or low) or work area temperature exceeds limits

- Filter end-of-life reminder

Pressure transducer monitors the resistance variation of the filter to determine the remaining life of the filter, and will warn the user when the remaining life is below 10%

- UV lamp end-of-life reminder

The microcomputer will monitor the service time of the UV lamp, and will warn the user to replace the UV lamp when its remaining life is less than 10%

- Interlocking feature to ensure high safety and reliability

- Patented technology includes: UV lamp, UV lamp interlocking control, front window, fan and interior light are interlocked to prevent any leakage of UV rays or microorganisms.
- Like the Type B2 safety cabinet with internal & external fans interlocked, the external fan will be activated immediately when the safety cabinet is powered on, and the internal fan will be deactivated immediately when the safety cabinet is powered off. When the air inflow is lower than the set limit, the internal fan will be deactivated, and the external fan will continue working, accompanied with audible and visual alarms. When the internal fan is deactivated while in operation, the external fan will continue operating, accompanied with audible and visual alarms

Key Components

- Ultra-Low Particulate Air (ULPA) Filter (U15)

- The ULPA filter is made from moisture-proof and fireproof glass fibers and has an efficiency up to 99.9995% filtering 0.12 μ m solid particles, fully complying with cleanliness requirements of the USA FED STD 209E Grade 1 (or ISO 14644-1 Grade 3)
- ULPA filter can supply vertical air flows to the workbench, preventing the samples from being contaminated
- The filter can be scanned point by point to ensure high performance, reliability and safety

- Maintenance-free fan system

- Forward centrifugal fan with air inflows at both sides of the motor, reducing noise to a very low level. It is self-cooling, low energy consumption, and high reliability
- Optimal balance between air supply and energy consumption
- Stable air flow for safety cabinet upon precise control of fan operating voltage

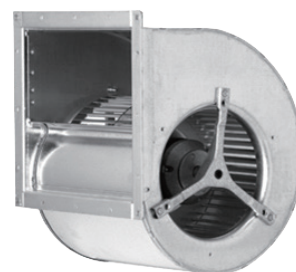
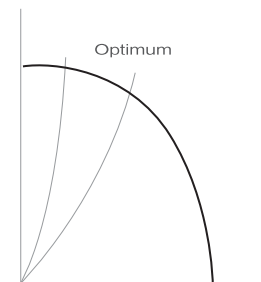
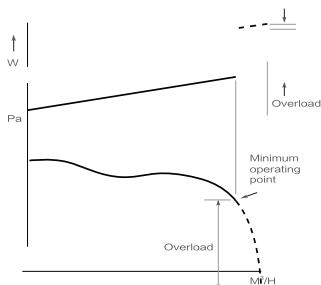

Biological Safety Cabinet: Classic Series, Type A2

Product Configuration



Specifications



Model		HR30-IIA2	HR40-IIA2	
General Specifications	Power Supply(V/Hz)	220-240/50/60	115/60 220-240/50/60	
	Power(VA)	1300	1300	
	Power of Blower(W)	AC 540/625	AC 540/625	
	Airflow Circulation	70% Downflow, 30% Exhaust	70% Downflow, 30% Exhaust	
	Main Filter Typical Efficiency	ULPA, U15, 99.9995%@0.12um	ULPA, U15, 99.9995%@0.12um	
	Exhaust Filter Typical Efficiency	HEPA, H14, 99.995%@0.3um	HEPA, H14, 99.995%@0.3um	
	Exhaust Filter	Single	Single	
	Filter's Brand	AirePlus	AAF	
	Downflow Velocity(m/s)	0.3	0.28 0.3	
	Inflow Velocity(m/s)	0.53	0.55 0.53	
Lighting Intensity (Lux)	≥1100	≥1200		
Sound Level(dB(A))	61	64		
Dimensions	Net/Gross Weight	kg	220/248	258/305
		lbs	485/546.7	568.8/672.4
	Internal Dimensions(W*D*H)	mm	900*610*680	1167*610*680
		in	35.4*24.0*26.8	45.9*24.0*26.8
	External Dimensions(W*D*H)	mm	1100*820*2200	1360*820*2200
		in	43.3*32.3*86.6	53.5*32.3*86.6
	Packing Dimensions(W*D*H)	mm	1185*945*1750	1445*945*1720
		in	46.7*37.2*68.9	56.9*37.2*67.7
Support Stand(mm)	680mm (standard), 680-900mm adjustable height (optional)		680mm (standard), 680-900mm adjustable height (optional)	
Sash Opening(mm)	190 (Max 490)		190 (Max 490)	
Container load (20'/40'/40'H)	10/20/20		8/16/16	
Alarm Functions	Alarm	Sound and Flash	Sound and Flash	
	Closing Fan Alarm After Door Opening	Y	Y	
	Door Ajar	Y	Y	
	Abnormal Inflow	Y	Y	
	Abnormal Downflow	Y	Y	
	Door Open More than Limit	Y	Y	
	Filter Clogging	Y	Y	
	Filter Damage	Y	Y	
	Filter Lifetime Lack	Y	Y	
UV light Lifetime Lack	Y	Y		
Accessories	UV Lamp	Y	Y	
	Socket	1 Socket	1 Socket	
	Valve Port	Standard with 2 Valve Port	Standard with 2 Valve Port	
	Side Wall Service Taps	Standard gas tap and vaccum tap, optional compressed air tap and water tap	Standard gas tap and vaccum tap, optional compressed air tap and water tap	
	Antimicrobial Powder Coating	Optional	Optional	
	316SS Work Surface	Optional	Optional	
	Work Surface	One-piece	One-piece	
	Touch Screen	N	N	
	Motorized Window	N	N	
	Foot Switch	N	N	
Armrest	Y	Y		
Exhaust Duct Connection Kits	Optional	Optional		
Others	Certification	CE, TUV	/ CE, TUV	

*Haier Biomedical reserves the right to change products and specifications without prior notice.

Optional components



Valve, yellow, for fuel gas (standard)



Valve, blue, for compressed air



Valve, grey, for vacuum (standard)



Valve, green, for water



1.5mm thickened workbench and liner

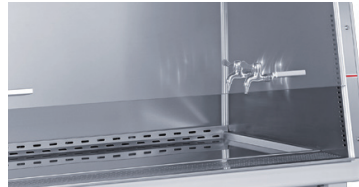

316 stainless steel workbench and liner



VHP sterilization kit



Type A2 BSC exhaust hood

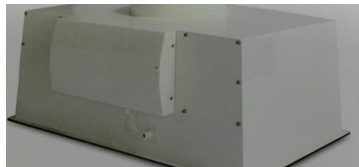

Activated carbon filter



Height-adjustable support



Europe, UK and USA standard power supply sockets



Europe, UK and USA standard power supply plugs



IR sterilizer

Product dimensions

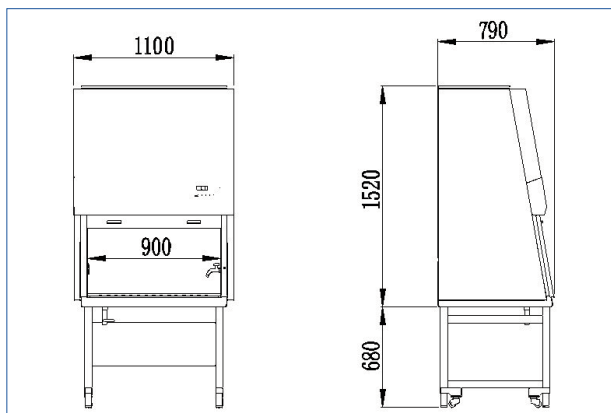

HR30-IIA2

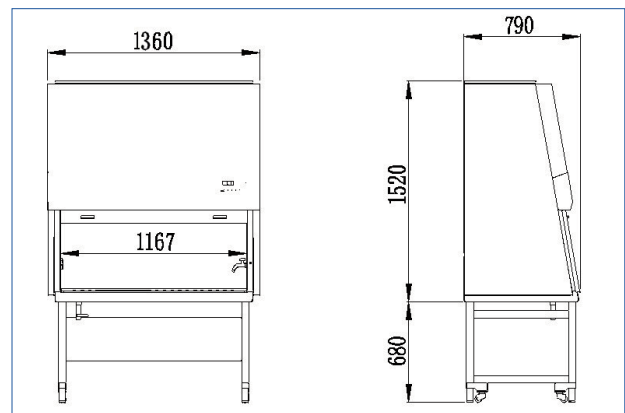

HR40-IIA2