



HYC-509T/509TF/1099T/1099TF



Smart 7" Touch Screen
with Real-time Display



Excellent Cooling Performance,
Temperature Uniformity $\pm 2^{\circ}\text{C}$



Multiple Alarm Functions
for Safer Monitoring

Qingdao Haier Biomedical Co.,Ltd.

No.280 Feng Yuan Road, High-tech Zone,
Qingdao, 266109, P.R. China
E-mail: inquiry@haierbiomedical.com
Website: www.haiermedical.com



Pharmacy Refrigerator

Scope of Application

Used for storage of medicines, vaccines, reagents, biological products and other items that require a temperature between 2-8°C in hospitals, pharmacies, pharmaceutical factories, clinics and laboratories etc.

Innovative Design

- Energy Efficient Hydrocarbon Refrigeration
- Self-closing Door Hinge with 90° Stop; Magnetic Gaskets to Ensure a Positive Seal



Haier Biomedical
International



Haier Biomedical
International



@haiermedicalint



Haier Biomedical
International



Haier Biomedical
International

Product Features



Microprocessor controller, 7" touch screen, easy to check the cabinet temp graph, alarm & event records and other information; authority management is standard to avoid unauthorized access or setting



Excellent cooling performance, temperature uniformity $\leq \pm 2^{\circ}\text{C}$; Anti-freezing thermostat is equipped as standard, DIN13277 compliance



Double-paned tempered glass door with electronic heater to reduce condensation even at 32°C , 80% RH ambient; self-closing door hinge with 90° stop; magnetic gaskets to ensure a positive seal (Solid door type is also available upon request)



Electromagnetic lock is standard to avoid unauthorized access



Energy efficient interior LED lighting



Standard USB module to easily record and export cabinet temperature and alarm data; Standard RS485 port and remote alarm contact for easily external connection; optional printer to easily export cabinet temp data



Eco-friendly hydrocarbon refrigerant (R600a) and CFC-free polyurethane insulation for reduced global warming potential



Hermetically sealed compressor, forced-air circulation with auto defrost to ensure high cooling performance



4 universal casters with 2 leveling feet



Adjustable plastic-coated wire shelves for improved circulation and flexible storage; Fully extendable ABS drawer with divider is optional



Multiple alarm functions for safer monitoring, audible/visual alert with mute function; remote alarm contact is equipped as standard



25mm probe access port on side wall to accept user-provided monitoring equipment



Product Details



Key lock

7" touch screen
microprocessor controller

LED light

Product simulator

Handle

NFC reader
together with electromagnetic

Product simulator

4 casters + 2 leveling feet

Printer (optional)

Electromagnetic lock

USB

Fingerprint reader
(optional)

Access port

Double layer glass door

Adjustable shelf

Fully extendable drawer
(optional)

Self-closing door hinge
with 90° stop

Product Dimension

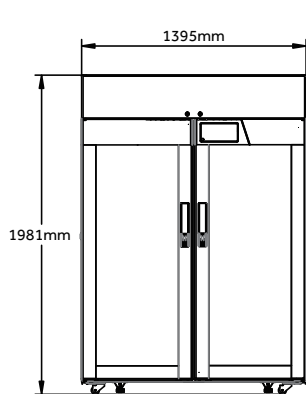

Front view

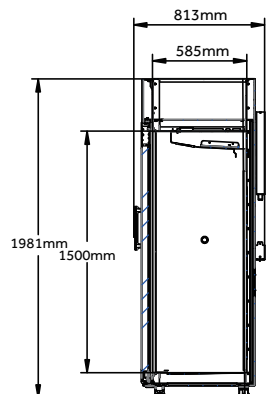

Side view

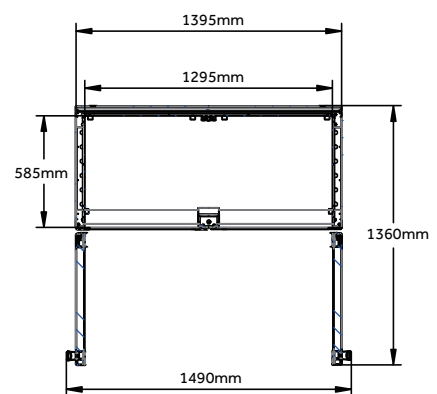

Top view

Specifications



Model		HYC-509T	HYC-509TF	HYC-1099T	HYC-1099TF	
Technical Data	Cabinet Type	Upright, Single Glass Door	Upright, Single Solid Door	Upright, Double Glass Door	Upright, Double Solid Door	
	Climate Class	N	N	N	N	
	Cooling Type	Forced Air Cooling	Forced Air Cooling	Forced Air Cooling	Forced Air Cooling	
	Defrost Mode	Auto	Auto	Auto	Auto	
	Refrigerant	HC	HC	HC	HC	
	Sound Level (dB(A))	40	40	43	43	
Performance	Temperature Range (°C)	2-8	2-8	2-8	2-8	
Control	Controller	Microprocessor	Microprocessor	Microprocessor	Microprocessor	
	Display	Touchscreen	Touchscreen	Touchscreen	Touchscreen	
Electrical Data	Power Supply (V/Hz)	220-240/50/60	220-240/50/60	220-240/50/60	220-240/50/60	
	Electrical Current (A)	1.85	1.75	2.5	2.25	
	Power Consumption (kWh/24h)	5.9	5.3	6.8	6	
Dimensions	Capacity (L/Cu.Ft)	509/17.97	509/17.97	1099/38.5	1099/38.5	
	Net/Gross Weight (approx)	kg	180/215	175/210	340/400	330/390
		lbs	396/473	385/462	748/1000	726/858
	Interior Dimensions (W*D*H)	mm	593*585*1500	593*585*1500	1295*585*1500	1295*585*1500
		in	23.21*22.9*58.8	23.21*22.9*58.8	50.7*22.9*58.8	50.7*22.9*58.8
	Exterior Dimensions (W*D*H)	mm	693*813*1981	693*813*1981	1395*813*1981	1395*813*1981
		in	27.1*31.9*77.7	27.1*31.9*77.7	54.7*31.9*77.7	54.7*31.9*77.7
	Packing Dimensions (W*D*H)	mm	835*915*2170	835*915*2170	1550*895*2100	1550*895*2100
		in	32.9*36.0*85.4	32.9*36.0*85.4	61.0*35.3*82.7	61.0*35.3*82.7
Container Load (20'/40'/40'H)	14/28/28	14/28/28	7/15/15	7/15/15		
Alarms	High/Low Temperature	Y	Y	Y	Y	
	High Ambient Temperature	Y	Y	Y	Y	
	Door Ajar	Y	Y	Y	Y	
	Power Failure	Y	Y	Y	Y	
	Low Battery	Y	Y	Y	Y	
	Sensor Error	Y	Y	Y	Y	
	Communication Failure	Y	Y	Y	Y	
	Condenser Overheat	Y	Y	Y	Y	
Accessories	Caster	Y	Y	Y	Y	
	Foot	Y	Y	Y	Y	
	Porthole	Y	Y	Y	Y	
	Shelves/Drawers	6/Optional	6/Optional	12/Optional	12/Optional	
	USB Interface	Y	Y	Y	Y	
	Remote Alarm	Y	Y	Y	Y	
Certification	Certification	CE, UKCA, DIN13277 (optional)	CE, UKCA, DIN13277 (optional)	CE, UKCA	CE, UKCA	

*Haier Biomedical reserves the right to change products and specifications without prior notice.