



HYC-85GD



Noise Level



Energy
Consumption



Reversible
Door Hinge

Pharmacy Refrigerator

Scope of Application

Used for storage of medicines, vaccines, reagents, biological products and other items that require a temperature between 2-8°C in hospitals, pharmacies, pharmaceutical factories, clinics and laboratories etc.

Innovative Design

- Purpose-built for medical and laboratory use
- High performance with low noise level
- Eco-friendly and energy saving
- Condensation free even at ambient 32°C & 80% RH
- Convenient monitoring and data acquisition

Qingdao Haier Biomedical Co.,Ltd.

No.280 Feng Yuan Road, High-tech Zone,
Qingdao, 266109, P.R. China
E-mail: inquiry@haierbiomedical.com
Website: www.haiermedical.com



Haier Biomedical
International



Haier Biomedical
International



@haiermedicalint















Haier Biomedical
International



Haier Biomedical
International

Product Advantages

-  Eco-friendly hydrocarbon refrigerant (R600a) and CFC-free polyurethane insulation for reduced global warming potential
-  Hermetically sealed compressor, forced-air circulation with auto defrost to ensure high cooling performance
-  Adjustable plastic-coated wire shelves for improved circulation and flexible storage
-  25mm probe access port to accept user-provided monitoring equipment
-  Optional USB, optional RS485 for easy data acquisition
-  Quiet operation with noise level of only 35 dB(A)
-  Triple layer glass door with frame heater to reduce condensation even at 32°C, 80% RH ambient; magnetic gaskets to ensure a positive seal
-  Multiple alarm functions for safer monitoring, audible/visual alert with mute function; remote alarm contacts as standard in rear of the unit
-  Easy to check the min/max temperature in the past 24 hours
-  Microprocessor controller, swipe clean display with 0.1°C resolution for accurate control
-  Energy efficient interior LED lighting
-  Site reversible door for flexible placement

Product Parts

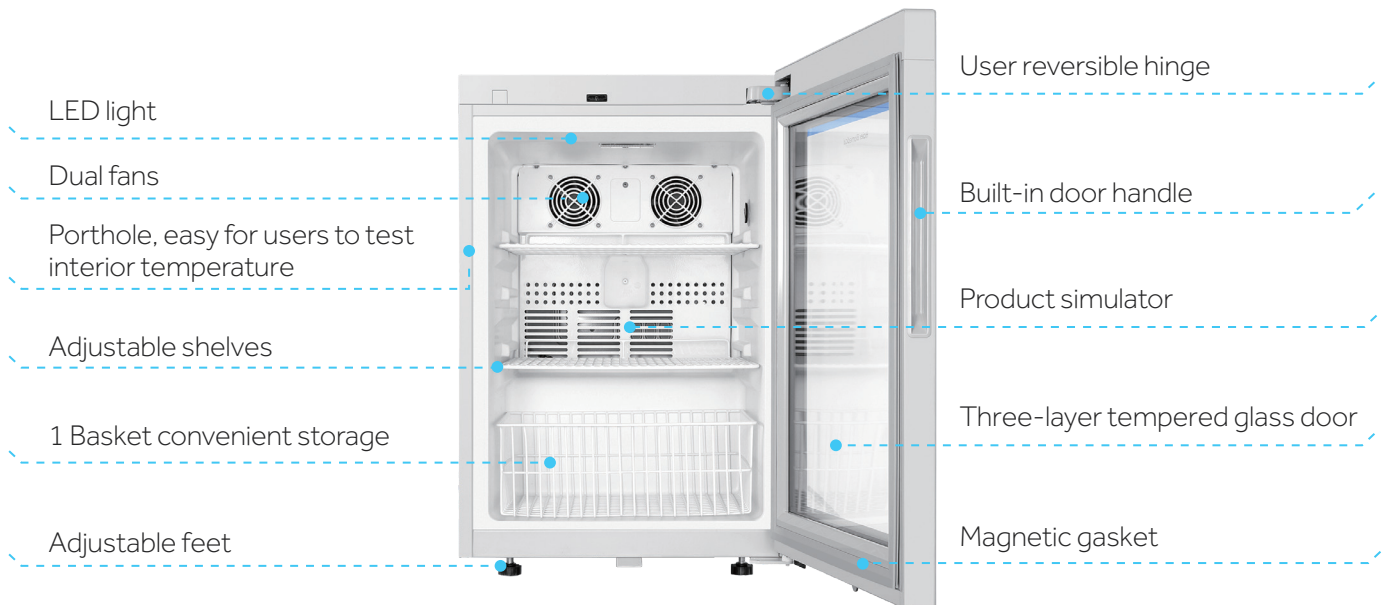

Product Dimension

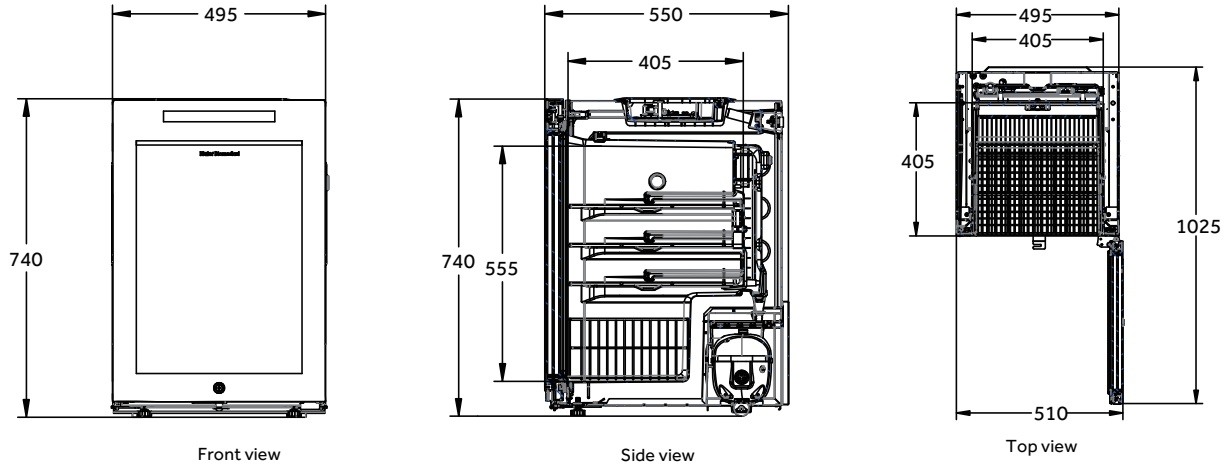

Specifications

Model		HYC-85GD		
Technical Data	Cabinet Type	Counter-top / Under-counter, Glass Door		
	Climate Class	N, 16-32°C		
	Cooling Type	Forced Air Cooling		
	Defrost Mode	Auto		
	Refrigerant	HC		
Performance	Sound Level (dB(A))	35		
	Temperature Range (°C)	2-8		
Control	Controller	Microprocessor		
	Display	LED		
Electrical Data	Power Supply (V/Hz)	220-240/50		
	Electrical Current (A)	0.98		
Dimensions	Capacity (L/Cu.Ft)	85		
	Net/Gross Weight (approx)	kg	36 / 41	
		lbs	79.4 / 90.4	
	Interior Dimensions (W*D*H)	mm	405*405*555	
		in	15.9*15.9*21.9	
	Exterior Dimensions (W*D*H)	mm	495*550*740	
		in	19.5*21.7*29.1	
Packing Dimensions (W*D*H)	mm	590*650*830		
	in	23.2*25.6*32.7		
Alarms	Container Load (20'/40'/40'H)	54/120/180		
	High/Low Temperature	Y		
	High Ambient Temperature	Y		
	Door Ajar	Y		
	Power Failure	Y		
	Low Battery	Y		
	Sensor Error	Y		
	Communication Failure	Y		
	Condenser Heat	N		
Remote Alarm	Y			
Accessories	Caster	2		
	Foot	2		
	Porthole	1		
	Shelves/Basket	2/1		
	USB Interface	Optional		
	RS485	Optional		
Others	Certification	CE, UKCA, DIN13277 (optional)		