



HYC-509/509F/1099/1099F



Excellent Cooling Performance,  
Temperature Uniformity  $\leq \pm 2^{\circ}\text{C}$



Multiple Alarm Functions  
for Safer Monitoring



Microprocessor Controller,  
Display with Resolution of  $0.1^{\circ}\text{C}$

# Pharmacy Refrigerator

## Scope of Application

Used for storage of medicines, vaccines, reagents, biological products and other items that require a temperature between  $2-8^{\circ}\text{C}$  in hospitals, pharmacies, pharmaceutical factories, clinics and laboratories etc.

## Innovative Design

- Energy Efficient Hydrocarbon Refrigeration
- Self-closing Door Hinge with  $90^{\circ}$  Stop; Magnetic Gaskets to Ensure a Positive Seal

**Qingdao Haier Biomedical Co.,Ltd.**

No.280 Feng Yuan Road, High-tech Zone,  
Qingdao, 266109, P.R. China  
E-mail: [inquiry@haierbiomedical.com](mailto:inquiry@haierbiomedical.com)  
Website: [www.haiermedical.com](http://www.haiermedical.com)



Haier Biomedical  
International



Haier Biomedical  
International



@haiermedicalint





Haier Biomedical  
International





Haier Biomedical  
International

**Product Features**

- 

Double-paned tempered glass door with electronic heater to reduce condensation even at 32°C, 80% RH ambient; self-closing door hinge with 90° stop; magnetic gaskets to ensure a positive seal
- 

Standard USB module to easily record and export cabinet temperature and alarm data; Standard RS485 port and remote alarm contact for easily external connection; optional printer to easily export cabinet temp data
- 

Microprocessor controller, digital display with 0.1°C resolution; easy to check the min/max temperature in the past 24 hours
- 

Multiple alarm functions for safer monitoring, audible/visual alert with mute function; remote alarm contact is equipped as standard
- 

Adjustable plastic-coated wire shelves for improved circulation and flexible storage; Fully extendable ABS drawer with divider is optional
- 

Excellent cooling performance, temperature uniformity  $\leq \pm 2^\circ\text{C}$ ; Anti-freezing thermostat is equipped as standard, DIN13277 compliance
- 

Convenient security with a top-mounted unique-key lock; electromagnetic lock is optional to avoid unauthorized access
- 

Hermetically sealed compressor, forced-air circulation with auto defrost to ensure high cooling performance
- 

Eco-friendly hydrocarbon refrigerant (R600a) and CFC-free polyurethane insulation for reduced global warming
- 

25mm probe access port on side wall to accept user-provided monitoring equipment
- 

Energy efficient interior LED lighting
- 

4 universal casters with 2 leveling feet

**Product Size Drawing**

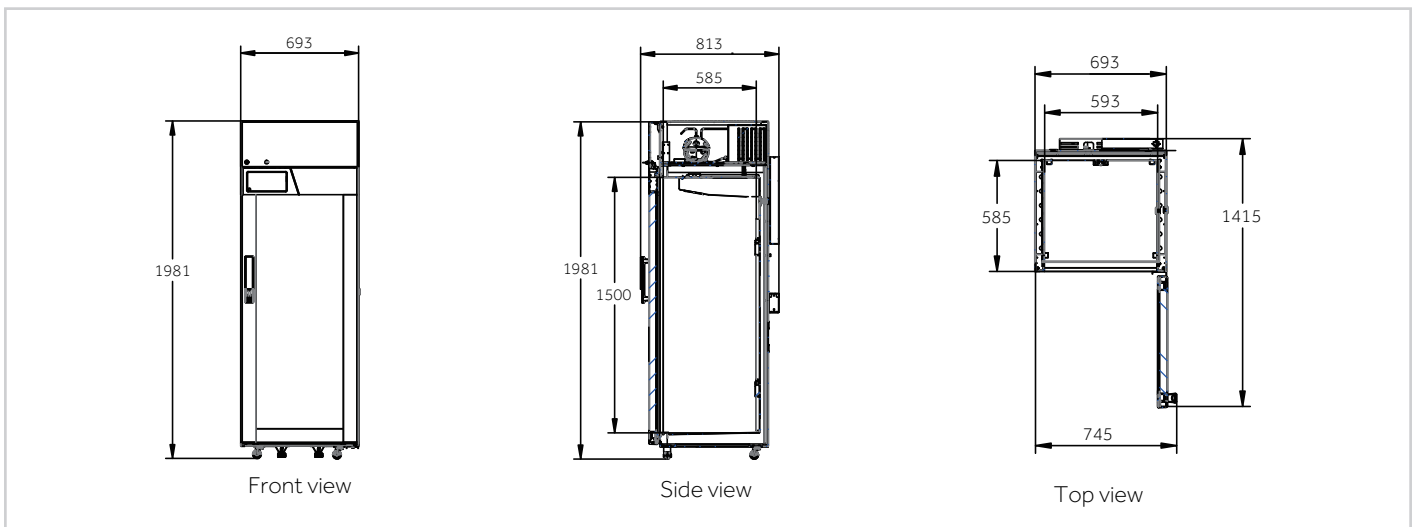

**Specifications**



Model		HYC-509	HYC-509F	HYC-1099	HYC-1099F	
Technical Data	Cabinet Type	Upright, Single Glass Door	Upright, Single Solid Door	Upright, Double Glass Door	Upright, Double Solid Door	
	Climate Class	N	N	N	N	
	Cooling Type	Forced Air Cooling	Forced Air Cooling	Forced Air Cooling	Forced Air Cooling	
	Defrost Mode	Auto	Auto	Auto	Auto	
	Refrigerant	HC	HC	HC	HC	
	Sound Level (dB(A))	40	40	43	43	
Performance	Temperature Range (°C)	2-8	2-8	2-8	2-8	
Control	Controller	Microprocessor	Microprocessor	Microprocessor	Microprocessor	
	Display	LED	LED	LED	LED	
Electrical Data	Power Supply (V/Hz)	220-240/50/60	220-240/50/60	220-240/50/60	220-240/50/60	
	Electrical Current (A)	1.85	1.75	2.5	2.25	
	Power Consumption (kWh/24h)	5.9	5.3	6.8	6	
Dimensions	Capacity (L/Cu.Ft)	509/17.97	509/17.97	1099/38.5	1099/38.5	
	Net/Gross Weight (approx)	kg	180/215	175/210	340/400	330/390
		lbs	396/473	385/462	748/1000	726/858
	Interior Dimensions (W*D*H)	mm	593*585*1500	593*585*1500	1295*585*1500	1295*585*1500
		in	23.21*22.9*58.8	23.21*22.9*58.8	50.7*22.9*58.8	50.7*22.9*58.8
	Exterior Dimensions (W*D*H)	mm	693*813*1981	693*813*1981	1395*813*1981	1395*813*1981
		in	27.1*31.9*77.7	27.1*31.9*77.7	54.7*31.9*77.7	54.7*31.9*77.7
	Packing Dimensions (W*D*H)	mm	835*915*2170	835*915*2170	1550*895*2100	1550*895*2100
		in	32.9*36.0*85.4	32.9*36.0*85.4	61.0*35.3*82.7	61.0*35.3*82.7
	Container Load (20'/40'/40'H)		14/28/28	14/28/28	7/15/15	7/15/15
Alarms	High/Low Temperature	Y	Y	Y	Y	
	High Ambient Temperature	Y	Y	Y	Y	
	Door Ajar	Y	Y	Y	Y	
	Power Failure	Y	Y	Y	Y	
	Low Battery	Y	Y	Y	Y	
	Sensor Error	Y	Y	Y	Y	
	Communication Failure	Y	Y	Y	Y	
	Condenser Overheat	Y	Y	Y	Y	
Accessories	Caster	Y	Y	Y	Y	
	Foot	Y	Y	Y	Y	
	Porthole	Y	Y	Y	Y	
	Shelves/Drawers	6/Optional	6/Optional	12/Optional	12/Optional	
	USB Interface	Y	Y	Y	Y	
	Remote Alarm	Y	Y	Y	Y	
Certification	Certification	CE, UKCA, DIN13277 (optional)	CE, UKCA, DIN13277 (optional)	CE, UKCA	CE, UKCA	

\*Haier Biomedical reserves the right to change products and specifications without prior notice.